

Model

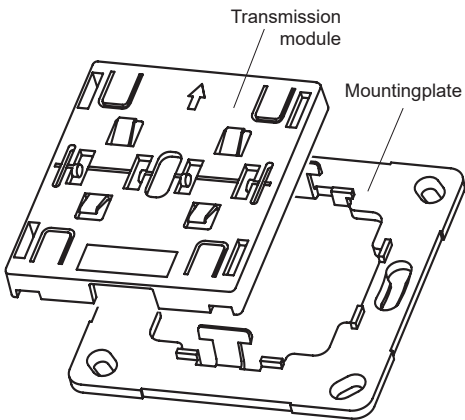

Technical Details

Frequency: 868.30 MHz
 Radiated power: 1.29 mW
 Modulation: FSK
 Coding: Easywave
 POTA
 Power supply: 1x 3-V-battery, CR2032
 Oper. temperature: -20 °C to +60 °C
 Range: free-field: approx. 150 m
 buildings: approx. 30 m
 Dimensions:
 Transmission module: 51,5/51/10,0 mm
 Mounting plate: 71/71/1,8 mm
 Weight: 34.0 g (incl. battery)

Safety Advice

- Before using the Radio Wall Switch, carefully read through the operating instructions!
- Also note the operating instructions of the receiver(s)!
- The Radio Wall Switch should only be operated within sight of the devices to be controlled! Otherwise persons could be placed in danger!
- Have faulty Radio Wall Switches checked by the manufacturer!
- Do not make any unauthorized alterations or modifications to the Radio Wall Switch!
- Keep the batteries out of the reach of children!

Scope of Delivery

Transmission module, battery CR2032, mounting plate, adhesive pads, operating instructions

Intended Use

Only use the radio wall switch RTS22/23 and RTS34/35 in dry indoor rooms to switch Easywave receivers.

The manufacturer shall not be liable for any damage caused by improper or non-intended use.

Function

The RTS22/23 und RTS34/35 are wireless switch transmitters for surface mounting in dry rooms. The buttons with format 55 (RTS22 and RTS23) fit into most cover frames with a cut-out dimension of 55x55 mm.

The format B6 buttons (RTS34 and RTS35) are suitable for the following Busch-Jaeger switch programs: carat, solo, Busch-axcent and future linear.

The cover frames of the corresponding switch ranges are not included in the scope of delivery.

By pushing a button the Easywave code A/B/C/D is transmitted and the connected Easywave receivers are switched in their selected operating mode:

- ON(A/C) or OFF (B/D)
- PULSE(A/B/C/D)
- UP(A/C) or DOWN(B/D)
- UP(A) / STOP(C/D) / DOWN(B)

RTS22E5002A11 for single rockers
 RTS23E5004A11 for double rockers

Application variants

SINGLE ROCKERS

ON/OFF or PULSE
 RTS22-ACC-02-xxP
 RTS34-ACC-01-xxP

UP/DOWN
 RTS22-ACC-03-xxP
 RTS34-ACC-02-xxP

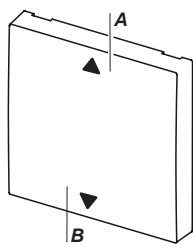
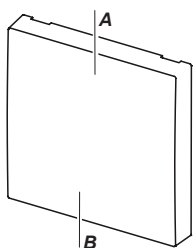

DOUBLE ROCKERS

ON/OFF (2x) or PULSE (4x)
 RTS23-ACC-01-xxP2
 RTS35-ACC-01-xxP

UP/DOWN (2x)
 RTS23-ACC-02-xxP2
 RTS35-ACC-02-xxP

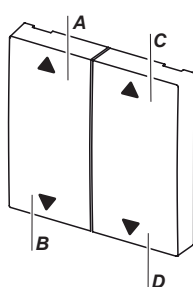
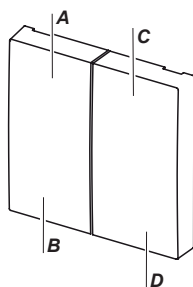

UP/STOP/DOWN
 RTS23-ACC-03-xxP2
 RTS35-ACC-03-xxP

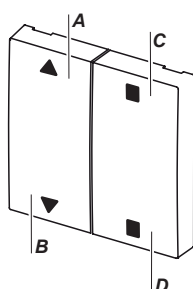

Start-Up

1. Screw or stick the mounting plate to the installation site with screws and dowels or the adhesive pads.
Caution: Make sure there is no interference with the wireless connection. Do not mount the device in a distribution box, in metal casings, in direct proximity to large metal objects, on the floor or close to it.
2. Insert the battery (see chapter „Insert / change battery“).
3. Place the cover frame onto the mounting plate and snap the transmission module to the catches on top and bottom. **The arrow on the transmission module has to point upwards.**
4. Plug the rocker(s) onto the transmission module.
5. Program the transmission code into the receivers. Please read the operating instructions supplied with the receivers.

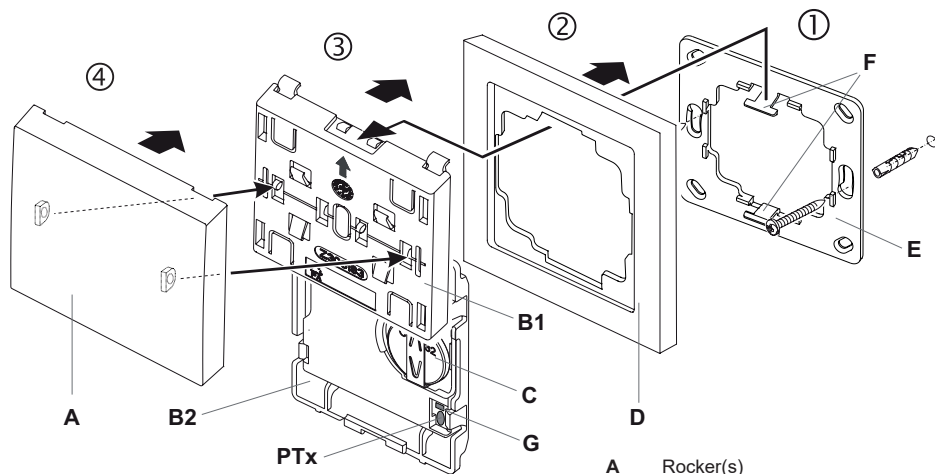

- A Rocker(s)
- B1 Transmission module front side
- B2 Transmission module back side
- PTx Learning button
- C Battery CR2032
- D Cover frame (not in the scope of delivery)
- E Mounting plate
- F Catches
- G Transmission LED

Insert / change battery

1. Lever off the transmitter module from the mounting plate.
2. Replace the battery. Only use batteries of the type CR2032. **Make sure the polarity is correct. The positive pole has to be visible!**
3. Place the transmitter module back onto the catches of the mounting plate.

Note: The coding of the transmitter is preserved even if there is no voltage supply. You do not need to program the code into the receivers again after a battery change.

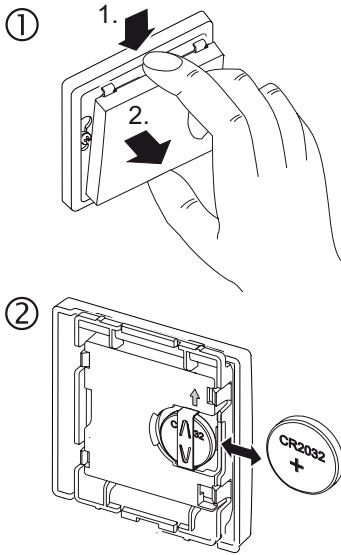

Remote learning function

The wall switch is equipped with the POTA (Programming Over The Air) remote learning function. This function can be used to reprogram a built-in and no longer accessible receiver if the wall switch has been programmed into it.

To find out whether a receiver supports this function, please refer to its operating instructions.

Troubleshooting

If the receiver does not react to the radio wall switch:

- Change the battery.
- Check that the wireless connection at the installation site is not impaired between the radio wall switch and the receiver.
- Program the transmission code into the receiver again.
- Other wireless devices using the same frequency and working in direct proximity may interfere with the device.

Disposal

Waste electrical products and batteries must not be disposed of with household waste!

Dispose of the waste product via a collection point for electronic scrap or via your specialist dealer.



Dispose of used batteries in a recycling bin for batteries or via the specialist trade.

Put the packaging material into the recycling bins for cardboard, paper and plastics.



Warranty

Within the statutory warranty period we undertake to rectify free of charge by repair or replacement any product defects arising from material or production faults.

Any unauthorized tampering with, or modifications to, the product shall render this warranty null and void.

Conformity



Hereby, ELDAT EaS GmbH declares that the radio equipment type RTS22 and RTS23 is in compliance with Directive 2014/53/EU.

The full text of the EU declaration of conformity is available at the following internet address: www.eldat.de

Service

If, despite correct handling, faults or malfunctions occur or if the product was damaged, please contact the company at the address below:

ELDAT EaS GmbH

Schmiedestraße 2

15745 Wildau

Germany

Phone: +49 3375 9037-310

Internet: www.eldat.de

E-Mail: info@eldat.de